

**Orchestra Reinforcement Microphones**

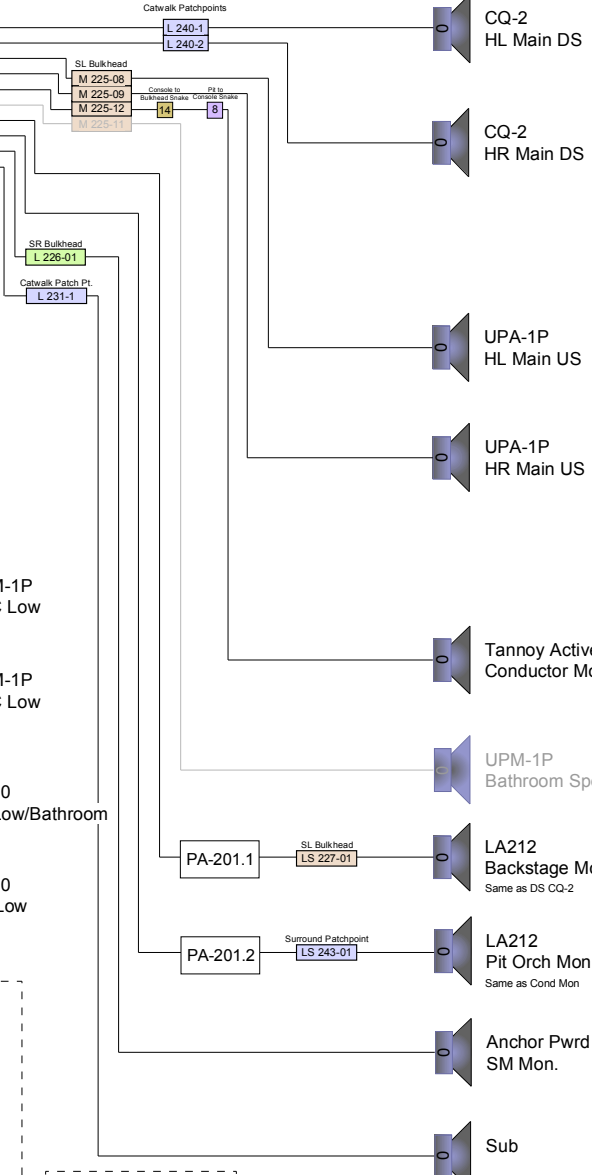

**Soundcraft K3 Internal Routing Outputs**

	Group Outputs								Aux Outputs							
	1	2	3	4	5	6	7	8	1	2	3	4	5	6	7	8
Orch Mic (Pan L)	X															
Piano Mic (Pan L)	X															
Strings Mic (Pan L)	X															
Woodwinds Mic (Pan L)	X															
Brass Mic (Pan L)	X															
Percussion Mic (Pan L)	X															
Maestro Mic (Pan L)	X															
Stage Mic 1 (Pan L)			X													
Stage Mic 2 (Pan R)				X												
Backstage Mic							X									
BkSt. Mic with Rev (Pan R)			X													
God Mic (RF) (Pan Center)								X								
God Mic (Center) (Wired)								X								
Video L				X	X											
Video R				X	X											
CD 1				X	X											
CD 2				X	X											
CD 2				X	X											
CD 2				X	X											

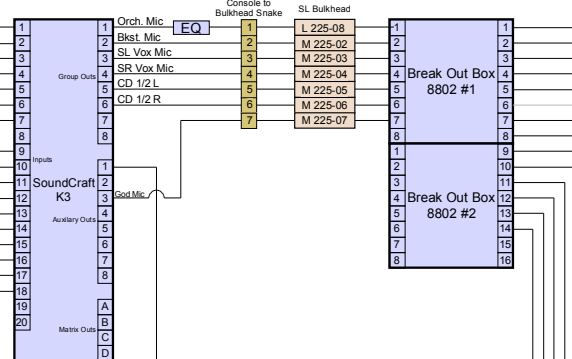
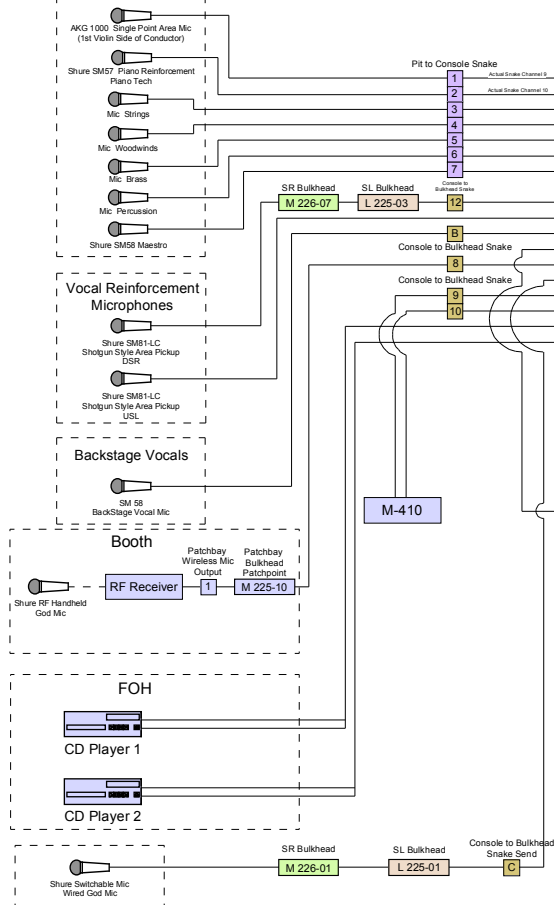
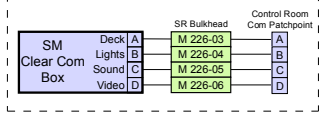

- Rack 1:**  
 Primary Soundcraft Power 3 Rack Spaces  
 Backup Soundcraft Power 3 Rack Spaces  
 [Already racked and movable]
- Rack 2:**  
 Furman Power Conditioner 1 Rack Space  
 Denon CD Player Control 3 Rack Spaces  
 Denon CD Player Disc Deck 3 Rack Spaces  
 Yamaha ProR3 Reverb Unit 2 Rack Spaces  
 2 Channel Graphic EQ 2 Rack Spaces

**Color Key**

- Console to Bulkhead Snake
- Console to Pit Snake
- Stage Right Bulkhead
- Stage Left Bulkhead

**Secret Codes**

MDC  
718  
305

**Bard Summerscapes**  
**Fischer Center**  
 60 Manor Avenue  
 Amundale-on-Hudson,  
 NY 12504-500

# Offenbach!

**Sound Schematic**  
 DIRECTOR: Ken Roht  
 SOUND DESIGNER: Amy Altadonna  
 Sound Engineer: Amy Altadonna  
 TECHNICAL DIRECTOR: John Starmer  
 DWG BY: Amy Altadonna  
 DWG DATE: 07/22/06

**SBD**